

PR-155 MIG Welder Component Sheet

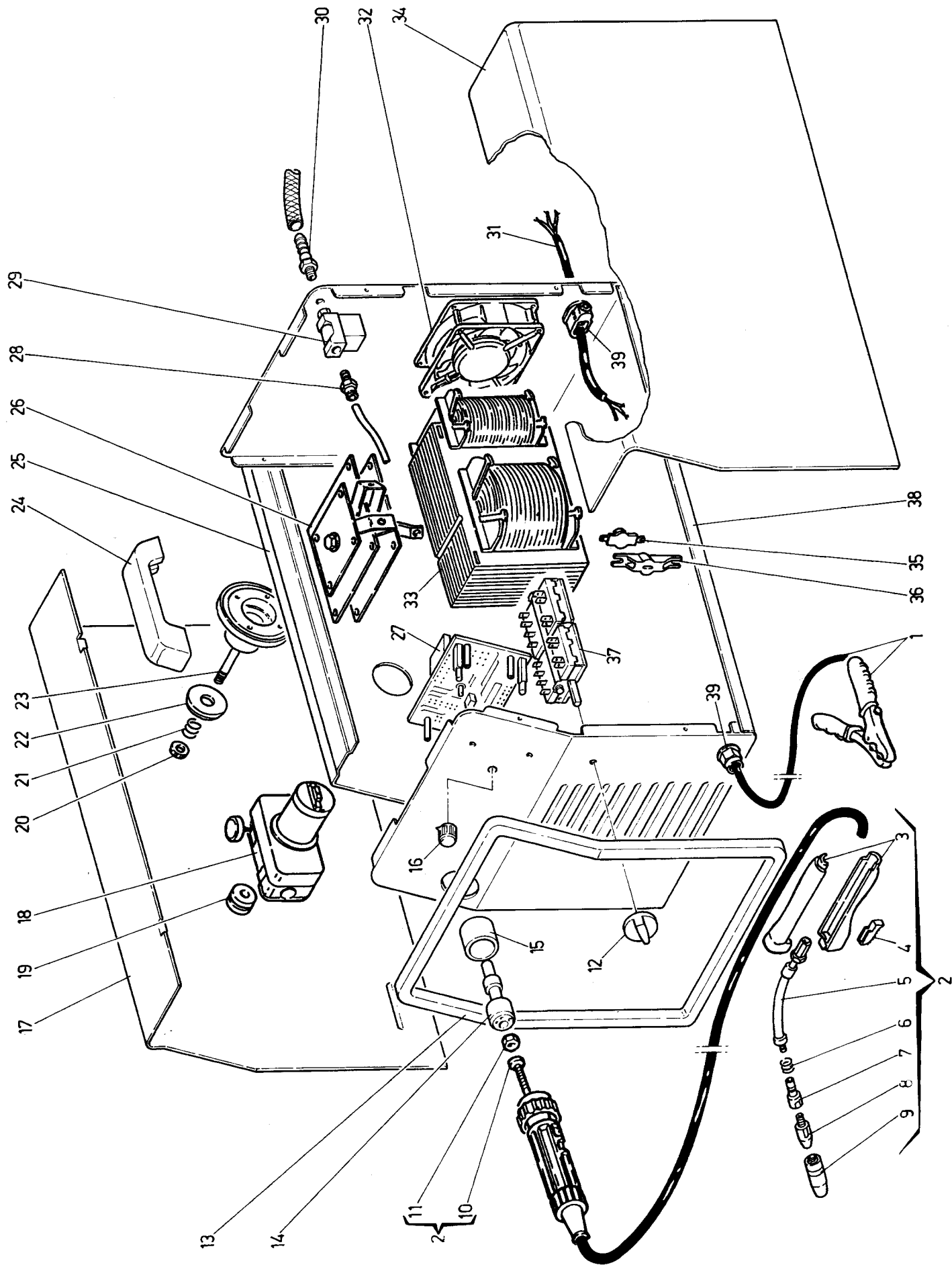



Item#	Part#	Description	Qty
1	PR155-11	Earth Cable	
2	PR155-01	Binzel Mb Torch 3m	
3		Handle	
4	PR155-21	Switch	
5	PR155-14	Swan Neck	
6	PR155-12	Spring	
7	PR155-16	Diffuser	
8	PR155-02	Contact Tip 0.6	
8B	PR155-03	Contact Tip 0.8	
9	PR155-04	Gas Nozzle	
10	PR155-15	Spiral Sheath (Liner)	
11		Nut	
12		Knob	
13		Frame	
14		Adaptor	
15		Adaptor Flange	
16	PR155-20	Knob	
17		Hinged Side Panel	
18	PR155-07	Wire Feed Motor	
19	PR155-34	Wire Feed Roller	
20		Ring	
21		Spring	
22		Coil Outer Support	
23		Coil Support	
24		Handle	
25		Inside Baffle	
26	PR155-09	Rectifier	
27	PR155-10	Circuit Board	
28		Fitting	
29	PR155-22	Solenoid Valve	
30	PR155-19	Fitting	
31		Power Cord	
32	PR155-06	Motor Fan	
33	PR155-24	Power Transformer	
34		Fixed Side Panel	
35	PR155-17	Thermostat	
36	PR155-18	Thermostat Support	
37	PR155-08	Switch	
38		Bottom	
39		Strain Relief	